

mackworth

CPP Portable Lift



User Manual

1	Introduction	4
1.1	Intended Use	4
1.2	Manufacture	4
1.3	European Authorised Representative	4
1.4	Symbols Used	5
1.5	Contraindications / Limitations	6
1.6	Safety Instructions and Warnings	6
1.7	Electromagnetic Compatibility (EMC) Statement	9
2	Configurations and Key Components	11
2.1	Product Configurations	11
2.2	Key Components	12
3	Applied Parts	13
3.1	Body Floating (BF) Applied Parts	13
3.1.1	Carry Bar	13
3.1.2	Slings	14
3.2	Handset	15
3.2.1	Re-attaching the Handset to the Portable Lift	15
3.2.2	Handset Storage	15
4	Portable Lift Operation	16
4.1	Turning the Portable Lift ON and OFF	16
4.2	Raising and Lowering the Carry Bar	16
4.3	Traversing the Portable Lift	17
4.4	Charging the Portable Lift	17
4.5	Emergency Stop	18
4.6	Emergency Lowering	18
5	Technical Specification	19
5.1	Portable Lift Dimensions	19
5.2	Specifications	20
5.3	LED Indications	21
5.4	Standards Applied	21
6	Environmental Conditions	22
6.1	Operating Environment	22
6.1.1	Normal Operating Conditions	22
6.2	Storage Conditions	22
6.2.1	Shipping and Storage Conditions	22
7	Daily Checks	23
7.1	Lift Tape Caution	23
8	Cleaning	24
8.1	Cover Cleaning	24
8.2	Lift Tape Cleaning	24
8.3	Disinfecting	24
9	Servicing	26

10 Troubleshooting..... 27

11 Disposal..... 28

12 Warranty 28

13 Service Record History 29

1 Introduction

This manual includes all variants of the CPP portable lift, along with the options for various track types.



Please read and understand this manual in its entirety before using your portable lift. The information in this manual is important for the safety of anyone near the portable lift and must be read and understood to help prevent injuries. It is also crucial to the proper operation and maintenance of the portable lift.

This user manual should be kept safe for future reference. Contents of this manual are subject to change without prior written notice.

Should any questions arise from reviewing this manual, contact your local authorised representative.

If, during the use of this device a serious incident occurs, please report it to the manufacturer and to your national authority.

1.1 Intended Use

The portable lift is a raising and lowering aid used to transfer people safely and is designed to be used in combination with a ceiling track, slings, or Free-Standing Gantry, together these three items make up the portable lift system. The portable lift makes it possible to move mobility impaired individuals with minimal strain or risk to the caregiver, while supplying complete safety, dignity and comfort for the person being moved. It can raise an individual from one location, such as a bed, move the individual along the track to another location and finally lower the individual into a chair or a bath. The portable lift is designed for internal use only. No other environments are suitable.

The portable lift is designed to be used by professional health care workers and home health care workers who may not have a specific range of skills in health care. Typical home care users may include, but is not limited to, teachers, medics, paramedics, carers, family, and friends. Focusing on the dignity and wellbeing of the person being moved, the simple to use portable lift maximises the amount of care provided to the person.

You may need to seek specialist advice on how to assist people with specific moving and handling needs. Sources of advice include, but is not limited to, professional bodies and organisations, occupational therapists, physiotherapists, manual handling advisers and ergonomists with experience in health and social care.

1.2 Manufacture

The product is manufactured at the address below:



Prism Medical UK

Unit 1, Tir Llwyd Industrial Estate, St Asaph Avenue, Kinmel Bay, Conwy, LL18 5JZ
Telephone number: 01924 840100.

1.3 European Authorised Representative

The address of the European Authorised Representative for this product:



European Healthcare & Device Solutions (Ireland) Ltd.
Stratton House, Bishopstown Road,
Cork, Ireland.
T12 Y9TC.
Telephone number: +353(86)2280846.

1.4 Symbols Used

The table below includes all symbols from BS EN ISO 15223-1:2021 that can be found in this manual and on the product and what they represent. Refer to this table when you are unsure of what a symbol stands for.

			
Place of Manufacture	Country of Manufacture	Serial number	Catalogue Number
			SWL
Caution – see instructions for use	Consult instructions for use	UK Conformity Assessed	Safe Working Load
			
For internal use only	Packaging indicator – Keep dry	Do not use if package is damaged	Packaging indicator – This way up
			
Fragile, handle with care	Please observe local laws on recycling	Non-sterile	Atmospheric pressure limitation
			IP_{N1N2}
Temperature range	Humidity range	Class II Equipment	Degree of protection provided by enclosure. N1: Ingress of particles N2: Ingress of water
			
Type 'B' applied part	Type 'BF' applied part	European Authorised Representative	

Table 1-1

1.5 Contraindications / Limitations

There are no known "contraindications" associated with the usage of portable lift, provided it is used as per the manufacturer's recommendations and guidelines. However, it is recommended that a client specific assessment is completed by a trained and knowledgeable health care professional to determine the method of transfer and use.

The manufacturer does not recommend a required number of operators for the use of our products. This information and recommendation can only be provided after a thorough personalised, case specific assessment, as there are many factors that can influence these decisions.

Limitations of the portable lift include:

- The portable lift should only be operated by competent and trained persons.
- The portable lift should only be used with patients weighing under the safe working load of the portable lift.
- Between the portable lift, sling, carry bar and track system, the lowest safe working load of the components should not be exceeded.
- The portable lift is only to be used within the track it is installed into. Portable lifts must only be moved by an authorised person.
- The portable lift is only compatible with the allocated slings found within this manual.
- Portable lifts are designed for human transfer only. There is no other application to this product.
- The operator of the portable lift must always pay attention to the well-being of the patient. Patients should not be left unsupervised during operation.
- The portable lift is not designed for self- lifting. A carer must operate the portable lift during use.

1.6 Safety Instructions and Warnings

Ensure to read and understand all the statements below, for the safety of the caregivers and users, along with warranty requirements. Failure to follow warnings in this manual may result in; injury to the operator and/or client and/or damage to the portable lift or related components.

- If you are unsure on the correct use of this product, please contact the manufacturer or a professional for further information or training.
- The portable lift and associated accessories are not toys. Do not use it for unsafe practices. Do not allow children to play with the product or any of its components. The portable lift should not be used for any practice except its intended use.
- In facilities where more than one operator will be responsible for using the portable lift, it is important that all such members be trained on the product prior to use. A training program should be set up by the facility to acquaint new operators with this equipment.
- Your guarantee is void if persons unauthorised by the manufacturer perform work on the portable lift.
- To maintain optimum function, the product should be inspected and maintained on a regular basis. See section 'Daily checks, Servicing and Cleaning' within this user manual.
- This user manual supplies a list of standard accessories that have been approved.
- The product and the associated accessories are intended only for lifting and transferring of a person. The manufacturer will not be responsible for any damage caused by the misuse, neglect, or purposeful destruction of the equipment and/or its associated components.
- Any accessories used with the product should be checked before each use to ensure that they are in good working order. Check for signs of wear and ensure that all labels are legible. Report any unusual wear to your local authorised dealer.

- Ensure that a clear space is kept around the portable lift. Before using the portable lift, always check for and move away any obstacles.
- Never leave a user unattended in the portable lift.
- If additional accessories have been supplied with the portable lift, refer to the instructions included with those items.
- The portable lift must be installed on the ceiling track or Free-standing Gantry prior to use.
- The portable lift must be installed only by persons authorized by the manufacturer.
- Under no circumstance should the portable lift, track, sling, or entire system be put in control of a person who has not been properly trained in the use and care of this equipment. Failure to adhere to this warning may result in significant injury to the operator, and / or the individual being lifted / transferred.
- Unauthorised modifications on this product may affect its safety. The manufacturer will not be held responsible for any accident, incident or deficiencies of performance that occur because of any unauthorised modification to its products. Your guarantee is void if any modifications are made that are not authorised by the manufacturer. This includes, but is not limited to, shortening the length of the emergency red cord – for example, tying it up or cutting it.
- There are no user serviceable parts inside the cover of the portable lift, likewise for any components of the associated parts. Do not remove cover screws, or open the portable lift unit, as this will VOID THE GUARANTEE/WARRANTY.
- Never expose the portable lift directly to water. Your guarantee does not cover any misuse or abuse of the portable lift system.
- The portable lift and associated accessories, track and sling(s) are intended only for lifting and transferring of a person. We will not be responsible for any damage caused by the misuse, neglect, or purposeful destruction of the portable lift, and/or its associated components.
- The installation of the portable lift and its associated parts are certified to a maximum load of 440 lb. Do not exceed the maximum rated load of any of the components.
- There is a risk of explosion if the portable lift is used in the presence of flammable anaesthetics.
- Your portable lift is for human lifting. Do not use it, or allow it to be used, for any other purpose.
- In areas where children are prone to be present be vigilant when using the portable lift.
- Protecting the people present, visually check sling loop connection points during raising, lowering and transfer stages so the sling stays firmly attached to the carry bar.
- To reduce the risk of unintended use, when the portable lift is not in use remove the sling(s) from the product to prevent entrapment or strangulation should the device be tampered with.
- The portable lift batteries are not a user serviceable part. Contact your local authorised dealer to arrange for replacement.
- Before first use, the portable lift unit must be charged for approximately 8 hours. Refer to section 'Charging the Portable Lift.' The handset must also be connected to the portable lift. To connect the handset, refer to the section 'Connecting the Handset to the Portable Lift.'

- Between the portable lift, carry Bar, sling and other accessories, the lowest maximum load shall always be used.
- A risk assessment must be performed before using any other manufactured sling, carry bar or ceiling track to ensure 'safe' use can be established.
- Risk of strangulation: Please make sure handset cable and lift tape are always clear of all persons.
- Risk of impact with carry bar: Please take care to ensure the carry bar is clear of the person in the sling when preparing to raise/lower and move them to avoid any contact with that person.
- Risk of collision: The person using the portable lift should make sure that when raising, lowering, or moving the portable lift that no people or objects will obstruct, be injured or damaged by the movement.
- Ensure that the person being hoisted is always raised clear of the floor when using the hoist.
- Ensure the lift tape is vertically aligned with the hoist when raising or lowering the carry bar. Any deviation from this can cause the tape to fray and result in its potential failure.
- Serious Injury: If, during the use of this device or because of its use a serious incident has occurred, please report it to the manufacturer and to your national authority.
- Electric Shock: Do not insert any objects into the portable lift case or battery charging station because of potential risk of electric shock. To reduce the risk of electric shock, do not install or use the battery charger with a damaged cable or if the unit has been dropped or damaged.
- Portable RF Communication Devices: Portable RF communications equipment (including peripherals, such as antenna cables and external antenna) should be used no closer than 30cm (12 inches) to any part of the portable lift, including cables specified by the manufacturer, otherwise degradation of the performance of this equipment could result.
- Vicinity to Other Equipment: Use of this equipment adjacent to or stacked with other equipment should be avoided, as it could result in improper operation. If such use is necessary, this equipment and the other equipment should be observed to verify that they are operating normally.
- Specified Accessories: Use of accessories, transducers, and cables other than those specified or provided by the manufacturer of this equipment could result in increased electromagnetic emissions or decreased electromagnetic immunity of this equipment and result in improper operation.



You may need to seek specialist advice on how to assist people with specific moving and handling needs. Sources of advice include, but is not limited to, professional bodies and organisations, occupational therapist, physiotherapists, manual handling advisers and ergonomist with experience in health and social care.

1.7 Electromagnetic Compatibility (EMC) Statement

The following statement has been made against the assumption that the user of the system utilises the provided components supplied by the manufacturer of the device to operate the device as intended. DO NOT use any other form of power charge with the system as the manufacturer's adapter has been assessed and complies with the EMC requirements.

This product, has been designed, manufactured, and tested in accordance with the legal requirements for the environment in which the device will be used within.

Pacemakers, defibrillators, and other medical devices should be manufactured in such a manner that they can withstand Electromagnetic Interferences (EMI) in accordance with their associated mandatory European directives and regulations. Please consult the user alert card which would have been issued to the user regarding the use of electrical items for those individuals fitted with these or any other devices.

If users of this equipment are unsure of its compliance to EMC, you can request the confirmation from the manufacturer that the product is manufactured to the appropriate Electromagnetic Compatibility standard.

A summary of the tests carried out in accordance with IEC 60601-1-2 is shown in the table below.

The portable lift is also classified as Class B according to CISPR 11:2009 for the home health care environment.

The use of the device within the correct area where the intended use is given will have no detrimental effect on other devices that have been tested to their intended respective requirements.

Section	Specification Clause	Test Description	Results	Comments/ Base Standard
Configuration and Mode: Test setup standby				
2.1	4.4.1	General Requirement; Risk Management Process for ME Equipment and ME Systems	Pass	
2.2	5	Identification, Marking and documents	Pass	
Configuration and Mode: Test setup charging				
2.3	7.1.1	Mains Terminal Disturbance Voltage	Pass	CISPR 11: 2009 A1:2010 EN 55016-2-3: 2004 + A1:2005
2.4	7.1.1	Electromagnetic Radiation Disturbance	Pass	CISPR 11: 2009 A1:2010 EN 55016-2-3: 2004 + A1:2005
2.5	7.2.1	Harmonic Current Emissions (AC Power Port)	Pass	EN 61000-3-2: 2014
2.6	7.2.2	Voltage Fluctuations and Flicker (AC Power Port)	Pass	IEC 61000-3-3: 2013
2.7	Table 4	Immunity to Electrostatic discharge (Enclosure Port)	Pass	IEC 61000-4-2 2008
2.8	Table 4	Immunity to Radiated RF Electromagnetic fields (Enclosure Port)	Pass	IEC 61000-4-3: 2006 A2:2010
2.9	Table 4	Immunity to Proximity Fields from RF Wireless Communication Equipment (Enclosure Port)	Pass	IEC 61000-4-3: 2006 A2:2010
2.10	Table 5	Immunity to Surges (AC Power Port)	Pass	IEC 61000-4-5: 2005
2.11	Table 5	Immunity to Electrical Fast Transient / Burst (AC Power Port)	Pass	IEC 61000-4-4: 2012
2.12	Table 5	Immunity to Conduct Disturbances Induced by RF Fields (AC Power Port)	Pass	IEC 61000-4-6: 2013

2.13	Table 5	Immunity to Voltage Dips and Voltage Variations (AC Power Port)	Pass	IEC 61000-4-11: 2004
2.14	Table 5	Immunity to Voltage Interruptions (AC Power Port)	Pass	IEC 61000-4-11: 2004
In-Track charging system stand testing				
2.7	Table 4	Immunity to Electrostatic discharge (Enclosure Port)	Pass	IEC 61000-4-2 2008
Configuration and Mode: Test setup standby				
2.4	7.1.1	Electromagnetic Radiation Disturbance	Pass	CISPR 11: 2009 A1:2010 EN 55016-2-3: 2004 + A1:2005
2.7	Table 4	Immunity to Electrostatic discharge (Enclosure Port)	Pass	IEC 61000-4-2 2008
2.8	Table 4	Immunity to Radiated RF Electromagnetic fields (Enclosure Port)	Pass	IEC 61000-4-3: 2006 A2:2010
2.9	Table 4	Immunity to Proximity Fields from RF Wireless Communication Equipment (Enclosure Port)	Pass	IEC 61000-4-3: 2006 A2:2010
Configuration and Mode: Test set up operating up and down				
2.4	7.1.1	Electromagnetic Radiation Disturbance	Pass	CISPR 11: 2009 A1:2010 EN 55016-2-3: 2004 + A1:2005
2.7	Table 4	Immunity to Electrostatic discharge (Enclosure Port)	Pass	IEC 61000-4-2 2008
2.8	Table 4	Immunity to Radiated RF Electromagnetic fields (Enclosure Port)	Pass	IEC 61000-4-3: 2006 A2:2010
2.9	Table 4	Immunity to Proximity Fields from RF Wireless Communication Equipment (Enclosure Port)	Pass	IEC 61000-4-3: 2006 A2:2010
Configuration and Mode: Test setup standby				
2.1	4.4.1	General Requirement; Risk Management Process for ME Equipment and ME Systems	Pass	
2.2	5	Identification, Marking and documents	Pass	

Table 1-7-1

2 Configurations and Key Components

2.1 Product Configurations

Below is a list of the track profiles that the portable lift can be installed into through the different configurations. The below profiles must match your pre-installed track for the portable lift to be installed. The table below includes all the configurations available with this portable lift.

Figure 2-1-1

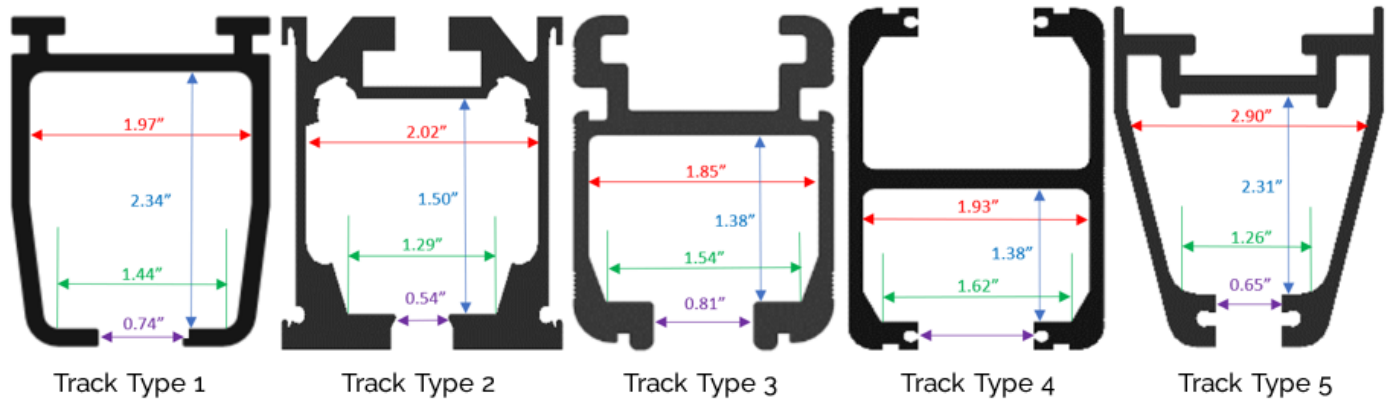

Portable Lift Type	Carry Bar Type	Track Type
CP440P – 108761	Black Carry Bar	Type 1
CP440P – 108778	White Carry Bar	Type 1
CP440P – 108762	Black Carry Bar	Type 2
CP440P – 108779	White Carry Bar	Type 2
CP440P – 108763	Black Carry Bar	Type 3
CP440P – 108780	White Carry Bar	Type 3
CP440P – 108764	Black Carry Bar	Type 4
CP440P – 108781	White Carry Bar	Type 4
CP440P – 108765	Black Carry Bar	Type 5
CP440P – 108782	White Carry Bar	Type 5
CP440P FSG – 108766	Black Carry Bar	FSG
CP440P FSG – 108783	White Carry Bar	FSG

Table 2-1-1

2.2 Key Components

Please see below to familiarise yourself with the components of the CPP portable lift. The images below show the contents of the portable lift. If you have not received all the components contact your local dealer at once – contact details are provided on the last page of this manual.

Item	Description
1	CPP Portable Lift
2	Info Label
3	Carry Bar
4	Handset
5	Portable Lift Charger
6	Reacher Pole
7	User Manual

Table 2-2-1

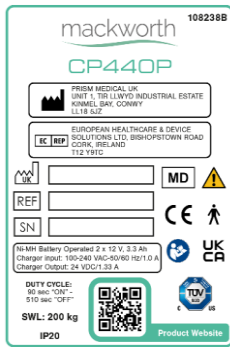

(Located on the portable lift's side cover)



Figure 2-1

3 Applied Parts

3.1 Body Floating (BF) Applied Parts

A Body floating applied part is a detachable component that has medium to long term contact with the user and carer. This includes the carry bar and sling.

Figure 3-1-1



Figure 3-1-2



Figure 3-1-3



3.1.1 Carry Bar

The carry bar is an essential applied part of the portable lift system. The carry bar incorporates three fixing point options at either end of carry bar, with a safety retaining clip on the outer hook. The carry bar is the link between the portable lift and the sling, allowing the user to be transferred. As per the guideline below, the black and white carry bars attached to the portable lift in the same way.

To attach the carry bar, see the guidelines below:

1. Open the red retaining tab on the QRS by pushing it down. (See figure 3.1.1.1)
2. Hold the carry bar horizontally and insert the boss into the QRS hook. (See figure 3.1.1.2)
3. Pivot the carry bar down to its natural position and release the retaining tab to secure. (See figure 3.1.1.3)



Figure 3-1-1-1



Figure 3-1-1-2



Figure 3-1-1-3

3.1.2 Slings

The sling is a specially designed fabric accessory that attaches to the portable lift using the carry bar. The sling is used to comfortably support the user during transfer. The sling is supplied separately from the portable lift at the initial time of purchase. To choose a suitable sling, the user should be assessed prior to purchase for their specific requirements. See list below for compatible slings that are recommended for use with this portable lift. For full list and further information on available slings, refer to the sling user manuals.

It is at the user's discretion to use alternative supplied product. In utilising another manufacturer's sling, checks must first be made to ensure the sling is safe to use and meets the requirements of BS EN ISO 10535 before its use and a full risk assessment to be carry out before use.

Always ensure that the sling SWL aligns with the portable lift, for any component found across the system, the lowest SWL must never be exceeded.

Mackworth Sling Range	Care-Ability Sling Range
Mackworth Oak	Universal
Mackworth Yew	Universal Deluxe
Mackworth Hazel	Toilet Access
Mackworth Willow	Hammock
Mackworth Beech	Classic Hammock
Mackworth Pine	Deluxe Hammock
	Comfort In Chair Hammock
	Split Leg in Chair Hammock

Table 3-1-2-1

The way the sling is attached to the carry bar needs to be assessed on individual basis and documented in the individual's care plan. Furthermore, the person attaching the sling should reference the slings user manual for the recommended colour coded loop attachment method, as well as the correct fitting requirements for the user. Only after the correct fitting requirements is fully understood should the sling loops be fitted onto the carry bar.

To attach the sling to the carry bar, follow the guidelines below:

1. Pull the safety retaining clip back to access the carry bar hook. (See figure 3.1.2.1)
2. Place the chosen sling loop onto the hook. (See figure 3.1.2.2)
3. Release the safety retaining clip to secure the loop onto the carry bar. (See figure 3.1.2.3)



Make sure the required loop(s) are on the correct hooks and are correctly positioned.



Figure 3-1-2-1



Figure 3-1-2-2



Figure 3-1-2-3

To remove the sling, simply reverse the process – pull back on the spring locking mechanism, lift the loop out of the hook and release the locking mechanism.

The sling should be attached to the black carry bar in the same way as the guideline above.

3.2 Handset

The handset is an essential applied part of the portable lift system. There are three buttons on the handset to operate the functions: raising and lowering the carry bar, as well as initiating the emergency lowering procedure if needed.



NEVER pull the portable lift along the track using the handset as this could have a detrimental effect on the performance of the portable lift.

3.2.1 Re-attaching the Handset to the Portable Lift

We recommend that the handset should never be detached from the portable lift, but in an instance that it becomes inadvertently detached. See guidelines below to reattach the handset.

1. Connect the plug located at the end of the handset to the portable lift connection located on the underside of the portable lift. Align the handset male connector to the portable lift female connector see Fig 3-2-1.
2. Once the two parts are aligned push the handset connector upwards in the portable lift port until it is fully connected and secure in place by twisting the thread lock on the handset connector until it is completely closed see Fig 3-2-2.
3. Test the handset by operating each button to ensure that the command functions as intended. (See operating instructions for further details)



A sturdy ladder or steps may be needed to access the underside of the portable lift to attach the hand controller. Caution should be used when this is required.

Figure 3-2-1



Handset Male connector



Portable Lift Female connector

Figure 3-2-2

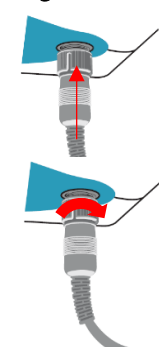

3.2.2 Handset Storage

The handset is designed to be stored in the handset case provided. For optimum storage and use, it is recommended the handset be placed in the handset dock, located on the wall at one end of the track system after every use. Traverse the portable lift back to the handset dock and place the handset into the dock. Make sure that the front of the handset is facing the wall with the attachment hook pointing away see Fig. 3-2-2-1. For more detail's information, please refer to the 'Charging the Portable lift' section.

The handset can also be stored on the carry bar as a secondary storage option. The Handset case has a hook attached to the rear, which will slot onto the carry bar (See Figure 3-2-2-2). It is advocated that the handset be always stored in the handset dock or on the carry bar when not in use for safekeeping and easy access.



Figure 3-2-2-1



Figure 3-2-2-2

4 Portable Lift Operation

4.1 Turning the Portable Lift ON and OFF

To turn the portable lift on press the toggle switch connected to the red cord on the portable lift see Fig 4-1-1, and to turn off pull the red cord down see Fig 4-1-2. Once the portable lift has been turned on the LED light that is located on side cover of the portable lift will display a steady green light, to indicate that power is available. The handset will 'wake-up' once any function button is pressed.

To conserve battery, the portable lift will automatically shut off after approximately two minutes of non-use.



Figure 4-1-1 - ON

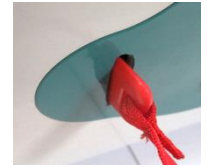

Figure 4-1-2 - OFF

4.2 Raising and Lowering the Carry Bar

To raise and lower the carry bar, operate the grey and green buttons found on the handset. The grey button raises, and the green button lowers the carry bar. The portable lift cover also provides these abilities, with the same colour coding performance functions, see Fig 4.2-1 This also aligns with the arrows found on the lift tape see fig. 4-2-2. The red button is the Emergency lowering function. Please see 'Emergency lowering' section for further details.

Figure 4-2-1

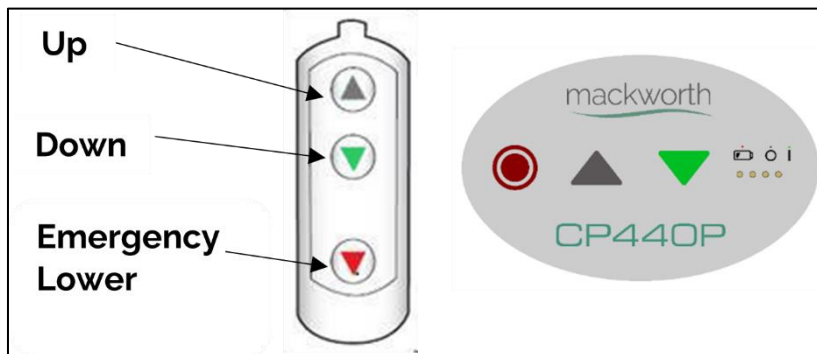
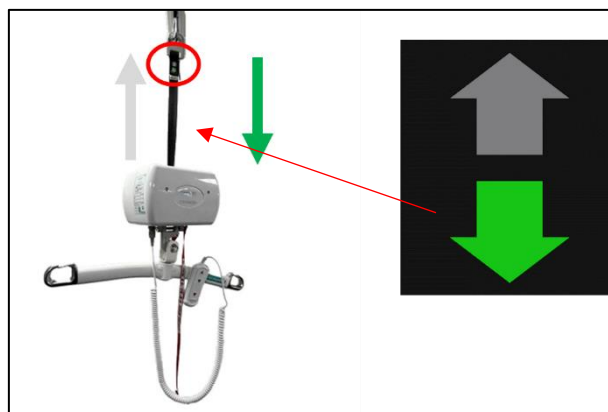

Figure 4-2-1



It is recommended that the operator hold the carry bar with one hand while raising/lowering is being done. This will stop the bar accidentally swaying and/or encountering an individual or close object. For the same reasons, raise the carry bar above head height when not in use and when traversing the unloaded portable lift.



In addition, the lifting tape must be kept vertically in line with the hoist when raising or lowering the carry bar. Any deviation from this can cause the tape to fray, leading to potential failure of the hoist. Please note that if the hoist fails due to improper handling, it will not be covered by warranty, and you will be liable for the cost of the replacement tape.

4.3 Traversing the Portable Lift



Always use extreme care when moving the portable lift along the track. Watch out for and avoid any obstructions that may cause injury to the individual in the sling, damage to the portable lift and/or to the obstruction.

NEVER pull the portable lift along the track using the handset, sling, or the emergency cord as this could have a detrimental effect on the performance of the portable lift.

The portable lift should be moved along the track by following the below guidelines:

1. Lower the carry bar to a suitable height to allow the carer to handle with both hands. Always ensure the user will be at a safe distance from the floor.
2. Push or pull the carry bar in the required direction for transfer. Ensure transfer is done safely and slowly for maximum user comfort.

4.4 Charging the Portable Lift

The portable lift is designed to be charged using the handset, by placing the handset into the charging dock, which should have been fitted to the wall at one end of the track system. This will ensure that the batteries are charged on a regular basis for peak performance and maximum life expectancy. The portable lift may remain connected to the charger indefinitely because the portable lift has a built-in regulator, removing the danger of overcharging. From full discharge, the batteries take up to 8.5hrs before they are fully charged.

To begin charging the portable lift, you must first open the small blue bung at the base of the handset to open the charging port, see Fig 4-4-1. Then place the handset into the charging dock as shown in the Fig. 4-4-2. The front of the handset will be facing towards the wall with the attachment hook facing away see Fig. 4-4-3. Slide the handset all the way into the dock and carefully push until the dock has attached to the handset port. To ensure the portable lift is charging, check the LEDs on the portable lift Cover are showing, charging, or charged.



Figure 4-4-1



Figure 4-4-2



Figure 4-4-3



When charging has been completed, ensure that the blue rubber bung at the base of the handset is inserted back into the charging port. This ensures that the stated IP compliance of the handset is maintained.

The portable lift LED lights indicates the remaining charge in the batteries. Please refer to 'LED Indications' for further detailed information. Once the batteries are low, the LED will display "yellow" and the portable lift will sound a two audible beep, 1 second apart in 3 cycles. The portable lift will no longer lift but will lower to allow the user to exit the portable lift.

4.5 Emergency Stop

The portable lift unit has an emergency shut-off feature that allows the operator to remove power to the portable lift. The emergency red cord/tab is located on a toggle switch on the underside of the portable lift. Pulling the toggle switch down using the red cord will shut the power off to the portable lift see Fig 4-4-1. This should only be used in an emergency. Once the red emergency cord has been initiated, the portable lift unit will need re-setting to operate again.

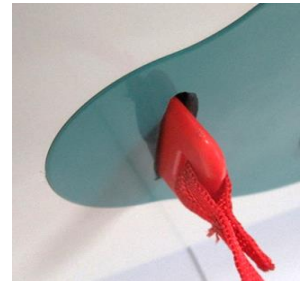

Figure 4-5-1

The user should not re-engage the switch once the cord has been pulled. If the emergency stop has been activated, contact your local authorised dealer to report the emergency and where applicable, a service engineer may be sent out to solve the issue with the portable lift. Do not continue to use the portable lift after using the emergency stop function before contacting the local authorised dealer.

4.6 Emergency Lowering

If the DOWN button on the handset does not function, or in power failure situations, the person may be lowered by pressing down and HOLDING the red emergency buttons, located on the handset or on the portable lift side cover.

Continually press the red button until the person is safely lowered to the desired position.

NOTE: The emergency lowering function does not provide a lifting function. The Emergency Lower should only be used in an emergency, such as lowering a patient due to damaged handset etc.

5 Technical Specification

5.1 Portable Lift Dimensions

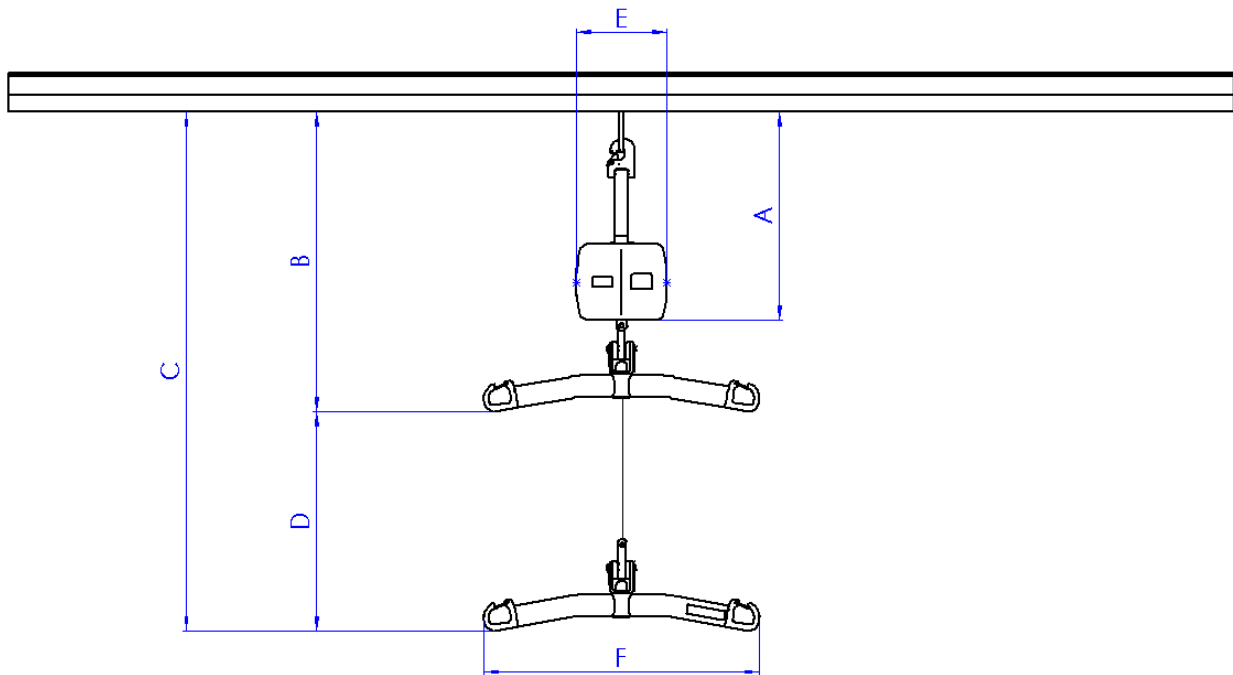

Figure 5-1-1

Dimensions in inches (Ref to drawing)	Portable Lift
A – Track to Portable Lift	6.3"
B – Min Distance from Track to Carry Bar	20.4"
C – Max Distance from Track to Carry Bar	99.1"
D – Lifting Range	20.4" – 99.1"
E – Portable Lift Depth	5.9"
F – Carry Bar Width	24.2"
Portable Lift Width	7.1"

Table 5-1-1

5.2 Specifications

Table 5-2-1

Portable Lift Specifications	
Safe Working Loads	
CPP Portable Lift	440lb
Lift Speeds	
Lifting Speed (0 lb)	1.2 in/s
Lifting Speed (110 lb)	1.1 in/s
Lifting Speed (220 lb)	1.1 in/s
Lifting Speed (286 lb)	1.0 in/s
Lifting Speed (440 lb)	0.82 in/s
Lowering Speed (0 lb)	1.06 in/s
Lowering Speed (110 lb)	1.36 in/s
Lowering Speed (220 lb)	1.39 in/s
Lowering Speed (286 lb)	1.41 in/s
Lowering Speed (440 lb)	1.49 in/s
Battery Specification	
Lead Acid Batteries – x2	24 V dc (2 x 12V) 3.3Ah Nimh
Battery Capacity – Raising/Lowering (Top 19.69" of Lift Tape) – (220 lb)	120 Lifts
Battery Capacity – Raising/Lowering (Top 19.69" of Lift Tape) – (286 lb)	100 Lifts
Battery Capacity – Raising/Lowering (Top 19.69" of Lift Tape) – (440 lb)	60 Lifts
Maximum Charging Time	8.5 hrs
Raising/Lowering Duty Cycle	15% use, 85% rest (90 seconds use, 510 seconds rest)
Component Weights	
Portable Lift	9.9 lb
Battery charger	1.1 lb
Carry bar	4.4 lb
Handset	0.44lb
Operational Forces	
Handset (Pneumatic)	3N
Emergency cord	15N
Hook locking mechanisms on lift tape	2.5N
Spring clips on carry bar	8N
Manually traversing fully loaded portable lift (SWL)	50N
Manually traversing unloaded portable lift (No weight)	10N
Charger Specification	
Charger Type	Handset Charging
Charger Input	100-240V AC 50/60Hz 1.5A
Charger Output	24VDC/1.0A
Motor Specification	
Portable Lift Motor	24VDC
Drive Motor (if applicable)	24VDC
Portable Lift Protection	
Portable Lift Case	Flame Retardant ABS
Portable Lift Case Degree of Protection	IP20
Handset Degree of Protection	IP24
Sound Level	
Sound Level	54 dB

5.3 LED Indications

The table supplies details on the LED colour, the audible beeping, and instructions on what actions to take when each message appears. This table may help for troubleshooting.

LED 1	LED 2	LED 3	LED 4	Buzzer	Function	Action
				No	75% - 100% Battery Capacity	None
				No	50% - 75% Battery Capacity	None
				No	25% - 50% Battery Capacity	None
				No	10% - 25% Battery Capacity	None
				2 Beeps (1 sec apart) x 3 cycles	0% - 10% Battery Capacity	Charge Hoist
				No	Hoist Charging	None
				No	Hoist charged (connected to charger)	None
				2 Beeps (0.5 sec apart)	Upper limit reached	Release Up button
				2 Beeps (1 sec apart)	Lower limit reached	Release Down button
				Solid Beep	Emergency lower Activated	General Information
				No	Hoist Standby/Switched Off	General Information
				1 Beep (1 sec apart) x 2 cycles	Maximum patient load exceeded	Review loading
				No	Motor - Max temperature exceeded	Allow Hoist to cool
				No	Battery - Max temperature exceeded	Allow Hoist to cool
				3 Beeps (0.5 sec apart) x 2 cycles	Motor current delta limit exceeded	Call Engineer Promptly
				4 Beeps (0.5 sec apart) x 2 cycles	Battery voltage delta exceeded	Call Engineer Promptly
				5 Beeps (0.5 sec apart) x 2 cycles	Battery temperature sensor fault	Call Engineer Immediately
				6 Beeps (0.5 sec apart) x 2 cycles	Charging system fault	Call Engineer Immediately
				7 Beeps (0.5 sec apart) x 2 cycles	Motor temperature sensor fault	Call Engineer Immediately
				8 Beeps (0.5 sec apart) x 2 cycles	Limit switch fault	Call Engineer Immediately

Table 5-3-1

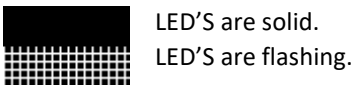

5.4 Standards Applied

The standards that have been applied to the device are as follows:

- IEC 60601-1-1:2012: Medical electrical equipment - Part 1: General requirements for basic safety and essential performance
- IEC 60601-1-2:2014: Medical electrical equipment - Part 1-2: General requirements for basic safety and essential performance - Collateral Standard: Electromagnetic disturbances - Requirements and tests
- IEC 60601-1-11:2010: General requirements for basic safety and essential performance - Collateral Standard: Requirements for medical electrical equipment and medical electrical systems used in the home healthcare environment.
- IEC 62366-1:2015: Medical devices - Part 1: Application of usability engineering to medical devices
- BS EN ISO 14971:2019: Medical devices. Application of risk management to medical devices
- BS EN ISO 12182:2012: Assistive products for persons with disability.
- BS EN ISO 10535:2006: Portable lifts for the transfer of disabled persons. Requirements and test methods
- Medical Device Regulation 2017/745 - CE marking of Medical Devices
- UK Medical Device Regulation 2002: UKCA marking of medical devices.
- EN ISO 15223-1:2016 - Medical devices. Symbols to be used with medical device labels, labelling and information to be supplied. General requirements
- EN 1041:2008+A1:2013 - Information supplied by the manufacturer of medical devices.
- BS ISO 20417 - Medical Devices - Information to be supplied by the manufacture.
- Waste Electrical and Electronic Equipment Directive (WEEE) 2012/19/EU

6 Environmental Conditions

The sections below will give detailed information regarding the environmental conditions the product should maintain throughout its life cycle. Failure to adhere to these conditions may negatively impact the function of the product. If you are unsure of any environmental conditions, always seek advice.

6.1 Operating Environment

The portable lift is intended to be used in dry environments. The portable lift is intended for internal use only.

The portable lift is intended to be used within a professional healthcare facility or home healthcare environment. The portable lift is not suitable for any other environment.

The portable lift is not intended to be used in environments where there are rapid changes in the environmental temperature and humidity.

The portable lift suffers little from any effects of lint, dust, and light.

- Lint – Due to the nature of the portable lift being installed closely to the ceiling, very little lint would be likely to gain access into the portable lift's workings. The portable lift is recommended as per Service Guide to be wiped cleaned during every portable lift inspection.
- Dust – Due to the nature of the portable lift being installed closely to the ceiling, very little dust would be likely to gain access into the portable lift's workings.
- Light – The user controls have been designed to be easily recognisable and the use of bright colours will help the user through all ranges of lighting. The Specification of the portable lift dictates that normal use would occur during ambient luminance 50 – 500 lux. Additional as the portable lift is designed for indoor use only, if required the user may wish to switch on room lighting. The LCD display on the portable lift is backlit to aid with user interaction.

6.1.1 Normal Operating Conditions

+5°C to +40°C (41°F to 104°F) at a relative humidity between 15% to 90% RH, non-condensing but not requiring a water vapour pressure greater than 50hPa and atmospheric pressure between 795hPa to 1060hPa.

6.2 Storage Conditions

The portable lift is intended for internal storage within normal environmental conditions. The portable lift is intended to be stored in a dry room.

It is not intended to be stored in environments where there are rapid changes in the environmental temperature.

When storing the portable lift, ensure that the product has been cleaned and dried. For further information, refer to the 'cleaning' section instructions.

6.2.1 Shipping and Storage Conditions

-25°C to +5°C (-13°F to 41°F) with any humidity level.

+5°C to +35°C (41°F to 95°F) at a relative humidity up to 90%.

+35°C to 70°C non-condensing at a water vapour pressure up to 50hPa.

12 Hours are required for the portable lift to cool from the maximum storage temperature until ready for its intended use when the ambient temperature is 20°C (68°F).

12 Hours are required for the portable lift to warm from the minimum storage temperature until ready for its intended use when the ambient temperature is 20°C (68°F).

7 Daily Checks

Inspection is to be completed prior to each use by the user of the portable lift.



Should any of the components in the table below fail the inspection, DO NOT use the portable lift. Contact your local authorized dealer for service – contact details are on the last page of this manual.

Ensure all component inspections in the table below are completed prior to each use of the portable lift.

Check List before Use:

Component	Service/Inspection required
Generic	Visual inspection of the external of the portable lift. Significant damage that may affect the function of the portable lift along with a clear safety hazard is unacceptable.
	Check the labelling on the portable lift to ensure they are all still legible, this includes the serial number and other important markings. If labels are not legible, then contact your local authorised dealer immediately.
	Check all nuts and bolts that are accessible and visible to see if they are loose, (such as the carry bar hook). If they are not tight or you have concerns, then contact your local authorised dealer immediately.
Emergency Stop Button	Check the emergency stop button functionality.
Carry Bar	Inspect the sling looped attachments for any damage, sharp edges, and excessive wear.
	Check the carry bar rotates and swings freely, and that there is no build-up of wear.
	Ensure the spring clips on the carry bar are functional and present.
Lift Tape	Inspect the lift tape for any signs of damage such as fraying, breaking, and tearing along its entire length. Ensure to also inspect the stitching on the tape for the same signs of damage.
QRS (Quick Release Hook)	Ensure that the locking device on the QRS is closed when the carry bar is attached.
	Inspect the QRS for damage such as cracking. And ensure that the locking device is functioning correctly.
LED's	Ensure that the LED's are all working correctly prior to use.
Trolley/Wheels	Ensure the wheels are traversing smoothly in the track before traversing a patient along the system. Listen for any unusual noises.
	Ensure that the locking device on the QRS is closed when attached to the trolley.
Motor	When raising and lowering the portable lift, with or without load, listen to the motor for any unusual lifting noises. Lower the patient immediately if an unusual noise is present.
Handset	Ensure the handset is functional, ensure the connection to the portable lift is correct and that all the buttons are working before operation with a patient.

7.1 Lift Tape Caution

The image (Figure 9-1-1) shows a badly worn lift tape. The portable lift should not be used until the lift tape has been replaced. Please contact your local dealer to arrange a service.



It is important to note that an incorrect alignment of the lift tape with the hoist could lead to tape fraying, causing delays in the hoist operation and additional expenses. For a smooth and safe operation, please ensure the lift tape is vertically in line with the hoist, when lowering or raising the carry bar.



Figure 7-1-1

8 Cleaning



To reduce the risk of cross-contamination it is recommended to clean the portable lift and accessories before use by a different person.

Please follow the recommended cleaning guidelines below on cleaning and disinfecting the portable lift.

8.1 Cover Cleaning

For cleaning, the covers can be cleaned using a damp cloth, soap/water, and antibacterial spray. Do not use a steam cleaner as this could damage the internals of the portable lift as well as label integrity. Do not use industrial bleaches, abrasive cleaners, or organic solvents.

All cleaning solutions must be thoroughly rinsed off the product at the end of the cleaning process and the product dried using a dry cloth/towel. Always ensure the product is dry before use.



Care should always be taken when cleaning around electrical components to reduce the risk of electric shock or damage to the portable lift.

8.2 Lift Tape Cleaning

Lift tapes can be wiped down using a dry cloth to remove any mild dirt and dust. When a spillage occurs, it is recommended that it be cleaned as quickly as possible to avoid any staining; it is good practice to dab the spillage and not to rub it as this could cause staining. For more persistent stains and dirt, hot water with an antibacterial spray can also be used.

All cleaning solutions must be thoroughly rinsed off the product at the end of the cleaning process and dried using a dry cloth/towel. Always ensure the product is dry before use.

8.3 Disinfecting

Should the portable lift require a more thorough cleaning, the use of the Actichlor™ disinfectant product (which is widely available in tablet form and used throughout the healthcare industry) is recommended.



Follow the manufacturer's safety instructions for the use of this cleaning product before use to ensure safe use for the operator and the user.
Ensure the cloth is damp before the cleaning process.

Application is through a clean damp cloth applied to wipe the product down. Use in the following dilutions to ensure an effective clean:

- Actichlor™ dissolvable chlorine tablets provide a concentration of 1000 ppm of available chlorine (0.1%) per 1 tablet.
- 1 tablet (1.7g formed tablet (x1)) will create a virucidal solution, diluted in 1 litre of water to provide effective means to clean a "dirty" product. This is also ideal for use after an outbreak of the Norovirus/winter vomiting and can be used as a precaution against C.Diff. It is effective against viruses, bacteria, spores, yeasts, and moulds.
- A minimum of 5 minutes contact time with the outer components is recommended to prevent virucidal infections, whilst maintaining the integrity of the product. The product can withstand a longer contact period, however a minimum of 5 minutes is required to provide an effective cleaning regime.
- Blood spills should be dealt with by an increased concentration of the solution – please refer to the instructions on the manufacturer's product labelling.

Dilution chart					
Product used as	Product condition	Concentration (ppm)	Dilution qty* (l)	Tablets per 1l (0.26gal)	Contact time (minutes)
Bactericidal	Clean	200	5 (1.32gal)	1	1
	Dirty	1000	1 (0.26gal)	1	5
Yeasticidal	Clean	200	5 (1.32gal)	1	1
	Dirty	1000	1 (0.26gal)	1	5
Fungicidal	Clean	2000	1 (0.26gal)	2	15
	Dirty	5000	1 (0.26gal)	5	15
Mycrobactericidal	Clean	1000	1 (0.26gal)	1	15
	Dirty	5000	1 (0.26gal)	5	15
Virucidal	Clean	500	2 (0.53gal)	1	5
	Dirty	1000	1 (0.26gal)	1	5
Sporcidal (C. Diff)	Clean	1000	1 (0.26gal)	1	10
	-	-	-	-	-
Sporcidal	Clean	5000	1 (0.26gal)	5	10
	-	-	-	-	-

- Dilution is made with water. DO NOT dilute within any other medium.
- When diluted in water, one tablet gives 1000ppm of available chlorine.
- The concentration of the solution depends upon whether the object being cleaned is noticeably dirty (indicated in the table by "Product condition.")

Table 8-3-1

Handling and storage safety precautions when using this cleaning agent:		
Advice on Safe Handling	Hygiene Measures	Conditions for Safe Storage
<p>Avoid contact with skin and eyes.</p> <p>Do not breathe dust, fumes, gas, mist, vapours, spray.</p> <p>Use only with adequate ventilation.</p> <p>Wash hands thoroughly after handling.</p> <p>Mixing this product with acid or ammonia releases chlorine gas.</p>	<p>Handle in accordance with good industrial hygiene and safety practice.</p> <p>Remove and wash contaminated clothing before re-use.</p> <p>Wash face, hands, and any exposed skin thoroughly after handling.</p>	<p>Keep out of reach of children.</p> <p>Keep container tightly closed.</p> <p>Store in suitable labelled containers.</p> <p>Storage temperature: 0-25°C (32-77°F).</p>
Individual Protective Measures	Dissolve	
Hand protection: Gloves	Dissolve in cold water – With no agitation, 1 tablet will take approximately 10 minutes to fully dissolve in the water used.	
<p>The information above has been extracted from the Actichlor™ MSDS (Manufacturers Safety Data Sheet). For a full review of the data please follow the link below:</p> <p>http://www.nhsggc.org.uk/media/236215/msds-actichlor-plus.pdf</p>		

Table 8-3-2

9 Servicing

Regular servicing on the portable lift will help prevent breakdowns and reduce repair costs. It will also improve the quality of the product for the end users.



To reduce the risk of injury, no service is to be carried out on the portable lift while in use. Service must be completed by an authorised service engineer only. Do not try to service the product yourself; this will void your warranty.

To ensure the safety and continued good function of your portable lift, it is recommended to have an approved service engineer perform a routine service every 6 months, this will ensure that the product meets the required standards. It is important to document the service history of the product in the service log found at the back of this user manual after each service.

When the product is serviced, the service checklist must be completed.
Service Manual Document Number: 995086.

For information about spare parts, refer to the spare parts manual.
Spare Parts Manual Document Number: 992086.

Contact your local authorised dealer if you:

- Need more information.
- Have any questions about the use or service of your product.
- Notice any change in the performance.
- Want to report an unexpected occurrence.
- Want to arrange a service.
- Need to find necessary information for replacement parts and components.

The expected product lifetime is **10 years**. This is dependent on usage and compliance with maintenance, servicing and LOLER inspections. Regular service on the product will increase the expected lifetime.

Serviceable parts within this period are batteries and the lift tape. Batteries should have an expected service life of 200 discharge cycles or 3 years, dependant on the charging routine. The lift tape should have an expected service life of 2 years if used correctly but visual inspection should be carried out before use.

10 Troubleshooting

Should a problem arise with the use of the portable lift, review the table below. Find the fault and complete the recommended solution. If the fault is not listed below or the solution does not correct the problem, contact your local authorised dealer at once – contact details are provided on the last page of this manual.

Fault	Action
The handset has become disengaged from the portable lift, or the Handset buttons are not responding.	Refer to the section 'Applied Parts.' If this does not correct the fault, then contact your local authorised dealer immediately so the portable lift can be checked to ensure proper continued operation.
The handset button command is continuously activated – UP, DOWN, E-LOWER.	Turn off the portable lift using the red pull cord. Contact your local authorised dealer immediately so that the portable lift can be checked to ensure proper continued operation.
No Power Part 1	If the emergency red cord has been used to stop, the portable lift will not operate again until it has been reset. Contact your local authorised dealer immediately so that the portable lift can be checked that it is safe to reset.
No Power Part 2	Operate the hand control to determine if the portable lift wakes up. This can be determined from the green LED. If not present, the portable lift may be out of charge. Place portable lift into the charging dock for a minimum of one hour to determine if this resolves the issue. If not, contact your local authorised dealer.
The portable lift LEDs show there is power, but the portable lift does not operate in the DOWN direction.	A built-in detector checks the slackness of the lift tape. This may be sensitive. Apply weight to the carry bar while pressing the DOWN button at the same time. If this corrects the fault temporarily but not permanently then contact your local authorised dealer so that the portable lift can be checked to ensure proper continued operation
The red indicator light on the portable lift turns RED and/or a loud alarm sound is heard when an individual is raised.	The batteries are low and require charging. Refer to section 'Charging the portable lift' and charge the portable lift for at least one hour before trying to raise/lower the carry bar. If this does not correct the fault, then contact your local authorised dealer immediately so that the portable lift can be checked to ensure proper continued operation.
The portable lift does not pass through a track part such as a turntable or gate.	Refer to the user manual of the specific piece of equipment in question. If the recommended solution does not correct the fault, then contact your local authorised dealer immediately so that the track part and portable lift can be checked to ensure proper continued operation.
Intermittent LED– Self Recovering	If the LED goes blank but self recovers, there is an electromagnetic disturbance in the vicinity, if the portable lift is still operational, continue to use, and investigate the source of the disturbance.
Intermittent Motor performance	This may be caused by an electromagnetic disturbance, if the portable lift still is operational, continue to use, and investigate the source of the disturbance. When the motor performance is compromised, contact your local service provider.

Table 12-1-1

11 Disposal

With efforts to improve the environment and reduce waste, where possible our products have been manufactured with recyclable materials. Below are our guidelines on recyclable materials and being environmentally friendly.

The portable lift should be disposed by an approved service engineer at the end of its life cycle. For guidelines on correct decommissioning procedures, refer to the commissioning guide: 996086.

Please see the local laws on recycling and respect the current laws for disposal within the community the product is being used within. If there is any uncertainty of the below guidelines, contact your local authorities to decide the proper method of disposal of potentially biohazardous parts and accessories.

Fully recyclables:	Consideration when Recycling:
Chassis	Batteries
Plastic Covers	Wiring Looms – electronics
Metallic Internals – Hub etc.	PCB
Initial packaging of the device (cardboard)	Hand Control
Metallic fixing – Screws etc.	Motors
Plastic Mouldings	Lift Tape
Carry Bar	Charger
Reacher Pole	
Trolley	

Table 11-1



The product may be contaminated and must be disinfected before recycling or disposal. See section on 'Cleaning' for further details.

12 Warranty

It is impossible for all the risks to be eliminated from use of this product, but to reduce risk and improve safe and proper use, the user should always read and understand the user manual before use. Product failure may occur due to lack of maintenance and care, misuse, unauthorised and improper servicing or alterations, improper storage, and environmental use, or through normal use wear and tear. These factors are all beyond the control from the manufacturer. These risks are taken on by the users.

The portable lift comes with a 1-year warranty covering all manufacture defects. Refer to your terms and conditions for more detailed information. The warranty is valid if the product has maintained its intended use and the user manual instructions have been followed. The warranty will not extend to the use of the product when used contrary to the user manual. This guarantee does not affect or in any way limit your statutory rights.

1. The liability of the manufacturer under the terms of this guarantee shall be limited to the replacement of the defective part(s) to the sales distributor, dealer, agent, person, or entity which purchased the equipment from the manufacturer. In no event shall the manufacturer incur liability for any consequential or unforeseeable losses.
2. This equipment guarantee shall be void if an authorised service engineer does not service the equipment, in accordance with the manufacturer's recommendations, or if any unauthorised persons carry out work on the equipment.
3. This guarantee does not apply to failure attributable to normal wear and tear, damage by natural forces, user neglect or misuse or deliberate destruction.
4. Do not try to service the product yourself, or the warranty is void.

13 Service Record History

Complete this section after each service, repair inspection and/or maintenance.

Date:	Time:
Service Type: Service Inspection <input type="checkbox"/> Repair <input type="checkbox"/> Other <input type="checkbox"/>	
Completed By: (Printed name) (Signature)	
Company:	
Remarks & Actions Taken:	
Product Left in A Safe & Usable Condition: Yes <input type="checkbox"/> No <input type="checkbox"/> (if no explain in actions above)	
Date:	Time:
Service Type: Service Inspection <input type="checkbox"/> Repair <input type="checkbox"/> Other <input type="checkbox"/>	
Completed By: (Printed name) (Signature)	
Company:	
Remarks & Actions Taken:	
Product Left in A Safe & Usable Condition: Yes <input type="checkbox"/> No <input type="checkbox"/> (if no explain in actions above)	
Date:	Time:
Service Type: Service Inspection <input type="checkbox"/> Repair <input type="checkbox"/> Other <input type="checkbox"/>	
Completed By: (Printed name) (Signature)	
Company:	
Remarks & Actions Taken:	
Product Left in A Safe & Usable Condition: Yes <input type="checkbox"/> No <input type="checkbox"/> (if no explain in actions above)	
Date:	Time:
Service Type: Service Inspection <input type="checkbox"/> Repair <input type="checkbox"/> Other <input type="checkbox"/>	
Completed By: (Printed name) (Signature)	
Company:	
Remarks & Actions Taken:	
Product Left in A Safe & Usable Condition: Yes <input type="checkbox"/> No <input type="checkbox"/> (if no explain in actions above)	
Date:	Time:
Service Type: Service Inspection <input type="checkbox"/> Repair <input type="checkbox"/> Other <input type="checkbox"/>	
Completed By: (Printed name) (Signature)	
Company:	
Remarks & Actions Taken:	
Product Left in A Safe & Usable Condition: Yes <input type="checkbox"/> No <input type="checkbox"/> (if no explain in actions above)	

Date:	Time:
Service Type: Service Inspection <input type="checkbox"/> Repair <input type="checkbox"/> Other <input type="checkbox"/>	
Completed By: (Printed name) (Signature)	
Company:	
Remarks & Actions Taken:	
Product Left in A Safe & Usable Condition: Yes <input type="checkbox"/> No <input type="checkbox"/> (if no explain in actions above)	
Date:	Time:
Service Type: Service Inspection <input type="checkbox"/> Repair <input type="checkbox"/> Other <input type="checkbox"/>	
Completed By: (Printed name) (Signature)	
Company:	
Remarks & Actions Taken:	
Product Left in A Safe & Usable Condition: Yes <input type="checkbox"/> No <input type="checkbox"/> (if no explain in actions above)	
Date:	Time:
Service Type: Service Inspection <input type="checkbox"/> Repair <input type="checkbox"/> Other <input type="checkbox"/>	
Completed By: (Printed name) (Signature)	
Company:	
Remarks & Actions Taken:	
Product Left in A Safe & Usable Condition: Yes <input type="checkbox"/> No <input type="checkbox"/> (if no explain in actions above)	
Date:	Time:
Service Type: Service Inspection <input type="checkbox"/> Repair <input type="checkbox"/> Other <input type="checkbox"/>	
Completed By: (Printed name) (Signature)	
Company:	
Remarks & Actions Taken:	
Product Left in A Safe & Usable Condition: Yes <input type="checkbox"/> No <input type="checkbox"/> (if no explain in actions above)	
Date:	Time:
Service Type: Service Inspection <input type="checkbox"/> Repair <input type="checkbox"/> Other <input type="checkbox"/>	
Completed By: (Printed name) (Signature)	
Company:	
Remarks & Actions Taken:	
Product Left in A Safe & Usable Condition: Yes <input type="checkbox"/> No <input type="checkbox"/> (if no explain in actions above)	

Date:	Time:
Service Type: Service Inspection <input type="checkbox"/> Repair <input type="checkbox"/> Other <input type="checkbox"/>	
Completed By: (Printed name) (Signature)	
Company:	
Remarks & Actions Taken:	
Product Left in A Safe & Usable Condition: Yes <input type="checkbox"/> No <input type="checkbox"/> (if no explain in actions above)	
Date:	Time:
Service Type: Service Inspection <input type="checkbox"/> Repair <input type="checkbox"/> Other <input type="checkbox"/>	
Completed By: (Printed name) (Signature)	
Company:	
Remarks & Actions Taken:	
Product Left in A Safe & Usable Condition: Yes <input type="checkbox"/> No <input type="checkbox"/> (if no explain in actions above)	
Date:	Time:
Service Type: Service Inspection <input type="checkbox"/> Repair <input type="checkbox"/> Other <input type="checkbox"/>	
Completed By: (Printed name) (Signature)	
Company:	
Remarks & Actions Taken:	
Product Left in A Safe & Usable Condition: Yes <input type="checkbox"/> No <input type="checkbox"/> (if no explain in actions above)	
Date:	Time:
Service Type: Service Inspection <input type="checkbox"/> Repair <input type="checkbox"/> Other <input type="checkbox"/>	
Completed By: (Printed name) (Signature)	
Company:	
Remarks & Actions Taken:	
Product Left in A Safe & Usable Condition: Yes <input type="checkbox"/> No <input type="checkbox"/> (if no explain in actions above)	
Date:	Time:
Service Type: Service Inspection <input type="checkbox"/> Repair <input type="checkbox"/> Other <input type="checkbox"/>	
Completed By: (Printed name) (Signature)	
Company:	
Remarks & Actions Taken:	
Product Left in A Safe & Usable Condition: Yes <input type="checkbox"/> No <input type="checkbox"/> (if no explain in actions above)	

Date:	Time:
Service Type: Service Inspection <input type="checkbox"/> Repair <input type="checkbox"/> Other <input type="checkbox"/>	
Completed By: (Printed name) (Signature)	
Company:	
Remarks & Actions Taken:	
Product Left in A Safe & Usable Condition: Yes <input type="checkbox"/> No <input type="checkbox"/> (if no explain in actions above)	
Date:	Time:
Service Type: Service Inspection <input type="checkbox"/> Repair <input type="checkbox"/> Other <input type="checkbox"/>	
Completed By: (Printed name) (Signature)	
Company:	
Remarks & Actions Taken:	
Product Left in A Safe & Usable Condition: Yes <input type="checkbox"/> No <input type="checkbox"/> (if no explain in actions above)	
Date:	Time:
Service Type: Service Inspection <input type="checkbox"/> Repair <input type="checkbox"/> Other <input type="checkbox"/>	
Completed By: (Printed name) (Signature)	
Company:	
Remarks & Actions Taken:	
Product Left in A Safe & Usable Condition: Yes <input type="checkbox"/> No <input type="checkbox"/> (if no explain in actions above)	
Date:	Time:
Service Type: Service Inspection <input type="checkbox"/> Repair <input type="checkbox"/> Other <input type="checkbox"/>	
Completed By: (Printed name) (Signature)	
Company:	
Remarks & Actions Taken:	
Product Left in A Safe & Usable Condition: Yes <input type="checkbox"/> No <input type="checkbox"/> (if no explain in actions above)	
Date:	Time:
Service Type: Service Inspection <input type="checkbox"/> Repair <input type="checkbox"/> Other <input type="checkbox"/>	
Completed By: (Printed name) (Signature)	
Company:	
Remarks & Actions Taken:	
Product Left in A Safe & Usable Condition: Yes <input type="checkbox"/> No <input type="checkbox"/> (if no explain in actions above)	

Date:	Time:
Service Type: Service Inspection <input type="checkbox"/> Repair <input type="checkbox"/> Other <input type="checkbox"/>	
Completed By: (Printed name) (Signature)	
Company:	
Remarks & Actions Taken:	
Product Left in A Safe & Usable Condition: Yes <input type="checkbox"/> No <input type="checkbox"/> (if no explain in actions above)	
Date:	Time:
Service Type: Service Inspection <input type="checkbox"/> Repair <input type="checkbox"/> Other <input type="checkbox"/>	
Completed By: (Printed name) (Signature)	
Company:	
Remarks & Actions Taken:	
Product Left in A Safe & Usable Condition: Yes <input type="checkbox"/> No <input type="checkbox"/> (if no explain in actions above)	
Date:	Time:
Service Type: Service Inspection <input type="checkbox"/> Repair <input type="checkbox"/> Other <input type="checkbox"/>	
Completed By: (Printed name) (Signature)	
Company:	
Remarks & Actions Taken:	
Product Left in A Safe & Usable Condition: Yes <input type="checkbox"/> No <input type="checkbox"/> (if no explain in actions above)	
Date:	Time:
Service Type: Service Inspection <input type="checkbox"/> Repair <input type="checkbox"/> Other <input type="checkbox"/>	
Completed By: (Printed name) (Signature)	
Company:	
Remarks & Actions Taken:	
Product Left in A Safe & Usable Condition: Yes <input type="checkbox"/> No <input type="checkbox"/> (if no explain in actions above)	
Date:	Time:
Service Type: Service Inspection <input type="checkbox"/> Repair <input type="checkbox"/> Other <input type="checkbox"/>	
Completed By: (Printed name) (Signature)	
Company:	
Remarks & Actions Taken:	
Product Left in A Safe & Usable Condition: Yes <input type="checkbox"/> No <input type="checkbox"/> (if no explain in actions above)	

Date:	Time:
Service Type: Service Inspection <input type="checkbox"/> Repair <input type="checkbox"/> Other <input type="checkbox"/>	
Completed By: (Printed name) (Signature)	
Company:	
Remarks & Actions Taken:	
Product Left in A Safe & Usable Condition: Yes <input type="checkbox"/> No <input type="checkbox"/> (if no explain in actions above)	
Date:	Time:
Service Type: Service Inspection <input type="checkbox"/> Repair <input type="checkbox"/> Other <input type="checkbox"/>	
Completed By: (Printed name) (Signature)	
Company:	
Remarks & Actions Taken:	
Product Left in A Safe & Usable Condition: Yes <input type="checkbox"/> No <input type="checkbox"/> (if no explain in actions above)	
Date:	Time:
Service Type: Service Inspection <input type="checkbox"/> Repair <input type="checkbox"/> Other <input type="checkbox"/>	
Completed By: (Printed name) (Signature)	
Company:	
Remarks & Actions Taken:	
Product Left in A Safe & Usable Condition: Yes <input type="checkbox"/> No <input type="checkbox"/> (if no explain in actions above)	
Date:	Time:
Service Type: Service Inspection <input type="checkbox"/> Repair <input type="checkbox"/> Other <input type="checkbox"/>	
Completed By: (Printed name) (Signature)	
Company:	
Remarks & Actions Taken:	
Product Left in A Safe & Usable Condition: Yes <input type="checkbox"/> No <input type="checkbox"/> (if no explain in actions above)	
Date:	Time:
Service Type: Service Inspection <input type="checkbox"/> Repair <input type="checkbox"/> Other <input type="checkbox"/>	
Completed By: (Printed name) (Signature)	
Company:	
Remarks & Actions Taken:	
Product Left in A Safe & Usable Condition: Yes <input type="checkbox"/> No <input type="checkbox"/> (if no explain in actions above)	

Date:	Time:
Service Type: Service Inspection <input type="checkbox"/> Repair <input type="checkbox"/> Other <input type="checkbox"/>	
Completed By: (Printed name) (Signature)	
Company:	
Remarks & Actions Taken:	
Product Left in A Safe & Usable Condition: Yes <input type="checkbox"/> No <input type="checkbox"/> (if no explain in actions above)	
Date:	Time:
Service Type: Service Inspection <input type="checkbox"/> Repair <input type="checkbox"/> Other <input type="checkbox"/>	
Completed By: (Printed name) (Signature)	
Company:	
Remarks & Actions Taken:	
Product Left in A Safe & Usable Condition: Yes <input type="checkbox"/> No <input type="checkbox"/> (if no explain in actions above)	
Date:	Time:
Service Type: Service Inspection <input type="checkbox"/> Repair <input type="checkbox"/> Other <input type="checkbox"/>	
Completed By: (Printed name) (Signature)	
Company:	
Remarks & Actions Taken:	
Product Left in A Safe & Usable Condition: Yes <input type="checkbox"/> No <input type="checkbox"/> (if no explain in actions above)	
Date:	Time:
Service Type: Service Inspection <input type="checkbox"/> Repair <input type="checkbox"/> Other <input type="checkbox"/>	
Completed By: (Printed name) (Signature)	
Company:	
Remarks & Actions Taken:	
Product Left in A Safe & Usable Condition: Yes <input type="checkbox"/> No <input type="checkbox"/> (if no explain in actions above)	
Date:	Time:
Service Type: Service Inspection <input type="checkbox"/> Repair <input type="checkbox"/> Other <input type="checkbox"/>	
Completed By: (Printed name) (Signature)	
Company:	
Remarks & Actions Taken:	
Product Left in A Safe & Usable Condition: Yes <input type="checkbox"/> No <input type="checkbox"/> (if no explain in actions above)	

Dealer/service contact details:

Contact details:

Mackworth USA
54 West Industrial Drive
O'Fallon, MO 63366 USA
314-889-1000
www.mackworthusa.com

Disclaimer

While every effort has been made to ensure the accuracy of information contained in this manual, no liability can be accepted by Mackworth for any errors or omissions. Mackworth operates a policy of continuous improvement. Specifications and other data are subject to change without notice.

